

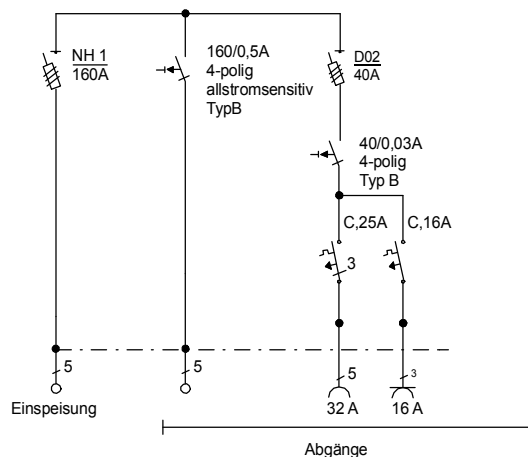

STEIDELE

Stromverteiler

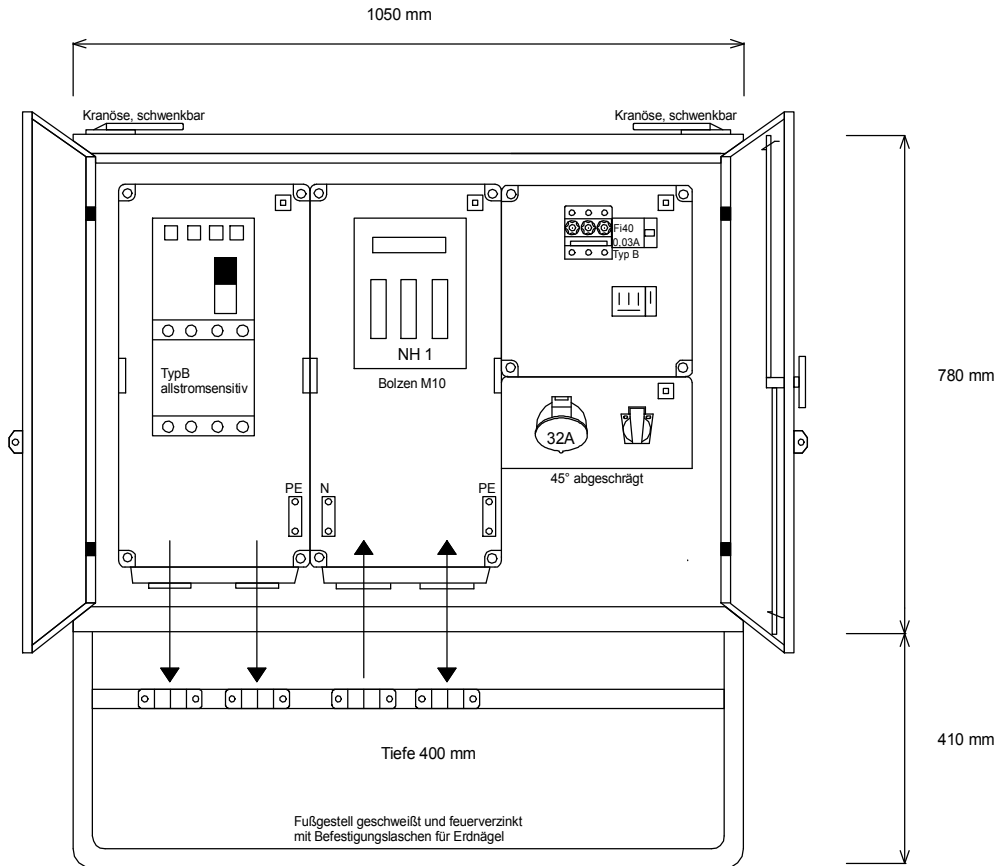
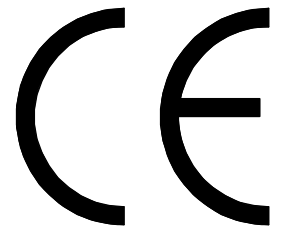

Entsprechend der neuen DIN VDE 0100-704/Okttober 2018

Typ: VK 160.2/0100-1-K

Verteiler nach EN 61439-4

Leistung 111 kVA, Gewicht ca. 82 kg, Gehäuse 79

Best.Nr. 7614

gezeichnet am/von:

23.03.2017 / Uffinger